

Mining



ENGINEERING CHAIN DIVISION

Tram Chains

Style A

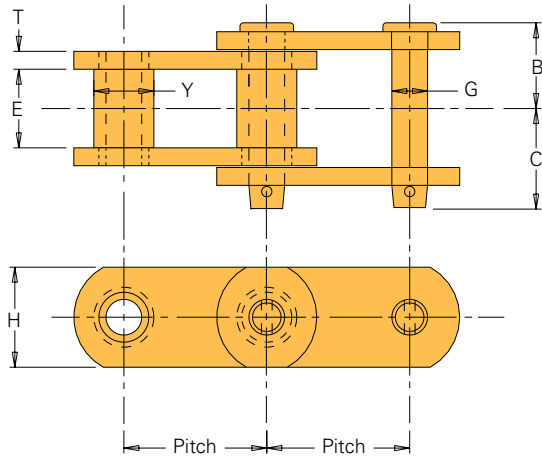

Style B

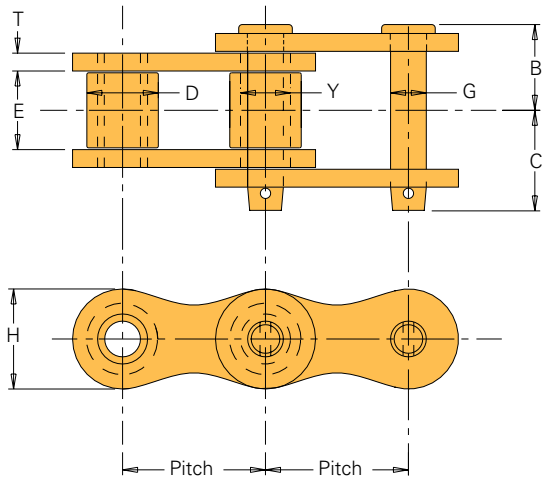

Tram Chain Specifications

All dimensions are in inches unless otherwise indicated.

Chain Number	Pitch	Style	Chain Width				Inside Width	Pins		Bushings		Rollers		Sidebars			Approx. Weight (lbs./ft.)
			Overall	Head to CL	End to CL	E		Dia.	Matl. ¹	Dia.	Matl. ¹	Dia.	Matl. ¹	Thick. ²	Height	Matl. ¹	
			(B+C)	B	C			G	Y	D	T	H					
US-2 ³	2.000	A	3.38	1.44	1.72	1.25	0.72	AHT	1.13	ACH	—	—	0.31	1.88	AHT	8.3	
US-64S	2.500	B	3.72	1.69	2.00	1.50	0.88	AHT	1.13	ACH	1.56	AHT	0.38	2.13	AHT	13.5	
US-64SH	2.500	B	4.13	1.91	2.22	1.50	0.88	AHT	1.13	ACH	1.56	AHT	.44x.50	2.37	AHT	14.5	

Indicates this chain is normally stocked. All others are made-to-order.

¹Material: AHT = Alloy heat-treated; ACH = Alloy case-hardened.

²US-64SH sidebar thickness on roller links is .50" and pin link .44".

³US-2 is a bushing type chain and does not have rollers.

Note: Dimensions are subject to change. Contact Engineering Chain Division of U.S. Tsubaki to obtain certified prints for design and construction.

U.S. Tsubaki, Inc.
Engineering Chain Division
(800)537-6140
www.ustsubaki.com

Mining



ENGINEERING CHAIN DIVISION

Standard Shuttle Car Chain

Standard Shuttle Car Chain

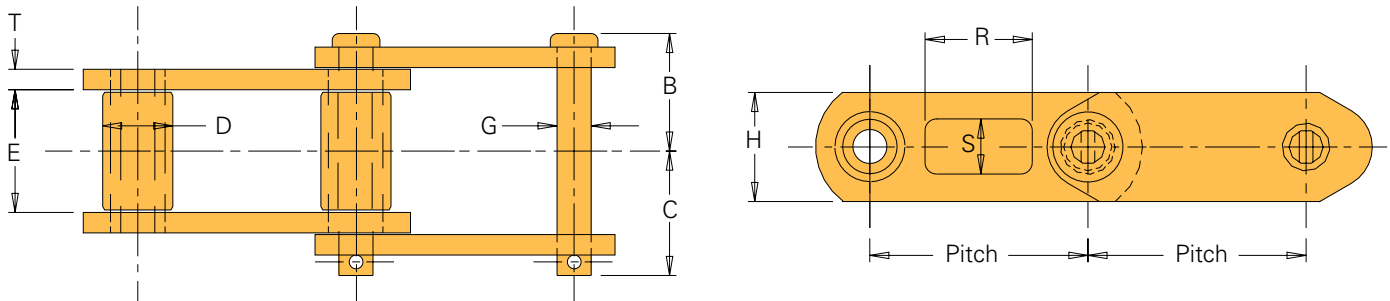

Standard Shuttle Car Chain Specifications

All dimensions are in inches unless otherwise indicated.

Chain No. ¹	Dwg. No.	Pitch	Space	Chain Width			Inside Width	Pins		Rollers		Sidebars			Attachments		Approx. Weight (lbs./ft.)
				Overall	Head to CL	End to CL		Dia.	Matl. ²	Dia.	Matl. ²	Thick.	Height	Matl. ²	R	S	
				(B+C)	B	C	E	G		D		T	H		R	S	
26001	17108	2.609	Ev. 6th	2.91	1.36	1.55	1.13	.56	AHT	1.13	ACH	.31	1.63	AHT	1.28	.66	6.3
26001	22304	2.609	Ev. 8th	2.91	1.36	1.55	1.13	.56	AHT	1.13	ACH	.31	1.63	AHT	1.28	.66	6.3
30701	22376	3.075	Ev. 6th	3.56	1.89	1.67	1.50	.63	AHT	1.25	ACH	.38	1.75	CHT	1.28	.66	8.8

Indicates this chain is normally stocked. All others are made-to-order.

¹Chain number 26001 has the slotted attachment hole on the cottered side only and Chain number 30701 has slotted attachment holes on both sides.

²Material: ACH = Alloy case-hardened; AHT = Alloy heat-treated; CHT = Carbon heat-treated.

Note: Dimensions are subject to change. Contact Engineering Chain Division of U.S. Tsubaki to obtain certified prints for design and construction.

U.S. Tsubaki, Inc.
 Engineering Chain Division
 (800)537-6140
www.ustsubaki.com



ENGINEERING CHAIN DIVISION

Super Shuttle 4

Super Shuttle 4—Shuttle Car Chain

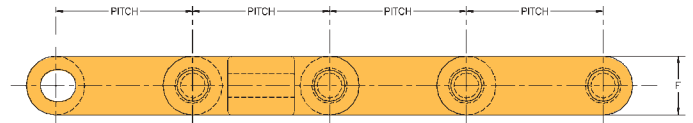
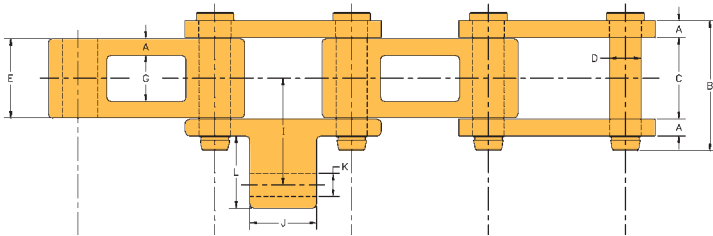

Super Shuttle 4—Shuttle Car Chain Specifications

All dimensions are in inches unless otherwise indicated.

Chain No.	Dwg. No.	Pitch	Style	Chain Width			Chain Dimensions							Attachments				Approx. Wgt. (lbs./ft.)	
				Overall	Sidebar Thick.	Inside	Pins		Cast Block			Sidebars		Space	I	J	K		L
							Dia.	Matl. ¹	Overall Width	Inside	Matl. ¹	Height	Matl. ¹						
B	A	C	D	E	G	F													
41001	23806	4.100	S ²	3.88	.50	2.44	.94	AHT	2.38	1.38	ADI	1.75	CHT	Ev.6th	3.19	2.00	.69	2.16	11.9

Indicates this chain is normally stocked.

¹Material: AHT = Alloy heat-treated; ADI = Alloy ductile iron; CHT = Carbon heat-treated.

²Indicates straight sidebar style.



ENGINEERING CHAIN DIVISION

Feeder Breaker Chain

Drawing Number 17071

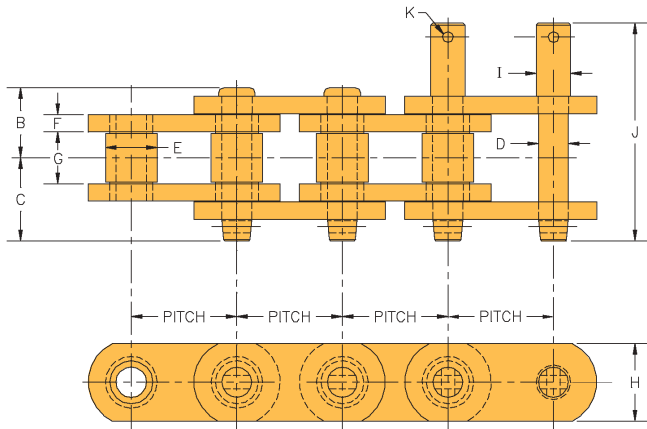

Drawing Number 22388 and 24023

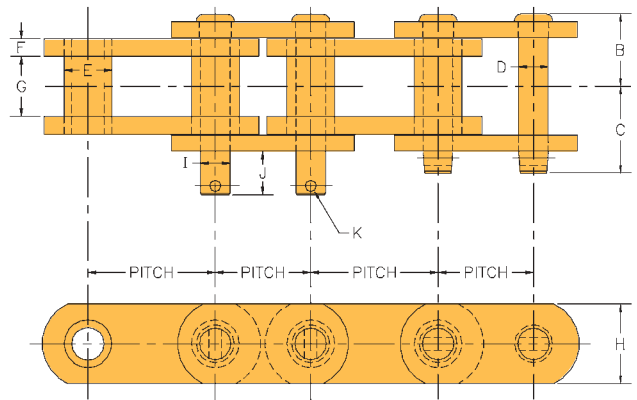

Feeder Breaker Chain Specifications

All dimensions are in inches unless otherwise indicated.

Dwg. No.	Pitch	Style	Chain Width			Inside Width	Chain Dimensions							Extended Pins				Approx. Weight (lbs./ft.)	
			Over-all (B+C)	Head to CL B	End to CL C		Pins		Bushings		Sidebars			Space	Dia. I	Length J	Hole Dia. K		Style
							Dia. D	Matl. ¹	Dia. E	Matl. ¹	Thick. F	Height H	Matl. ¹						
22388	3.000 4.000	S ²	5.00	2.28	2.72	1.88	.99	AHTIH	1.50	ACH	.56	2.50	AHT	Ev. 6th	.93	1.38	.36	T-Head	19.3
24023	3.000 4.000	S ²	5.00	2.28	2.72	1.88	.99	AHTIH	1.50	ACH	.56	2.50	AHT	Ev. 6th	.93	1.38	.36	Driv-Lok E Pin	19.3
17071	3.067	S ²	4.44	2.03	2.41	1.50	.87	AHTIH	1.50	ACH	.50	2.25	AHT	Ev. 6th	1.00	6.31	.31	T-Head	16.3

Indicates this chain is normally stocked.

¹Material: AHTIH = Alloy heat-treated induction hardened; ACH = Alloy case-hardened; AHT = Alloy heat-treated.

²Indicates straight sidebar style.

Note: Dimensions are subject to change. Contact Engineering Chain Division of U.S. Tsubaki to obtain certified prints for design and construction.

U.S. Tsubaki, Inc.
Engineering Chain Division
(800)537-6140
www.ustsubaki.com

Mining



ENGINEERING CHAIN DIVISION

Wash Box Chain

Wash Box Chain

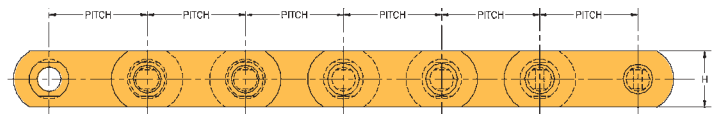
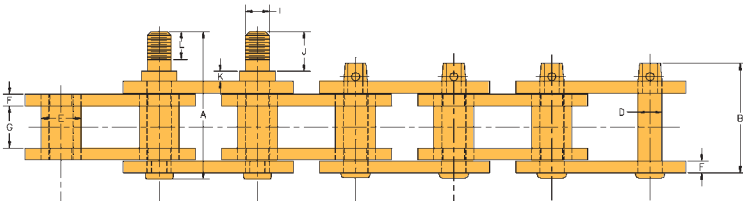

Wash Box Chain Specifications

All dimensions are in inches unless otherwise indicated.

Dwg. No.	Pitch	Style	Chain Width		Inside Width	Chain Dimensions							Extended Pins				Approx. Weight (lbs./ft.)	
			Overall	With Ext.Pin		Pins		Bushings		Sidebars			Space	Dia.	J	K		L
						Dia.	Matl. ¹	Dia.	Matl. ¹	Thick.	Height	Matl. ¹						
B	A	G	D	E	F	H	I	J	K	L								
14143	3.075	S ²	3.44	4.69	1.31	.75	ACH	1.25	CCH	.38	1.75	CHT	Ev. 6th	.75	1.25	.31	.88	9.8

Indicates this chain is normally stocked. All others are made-to-order.

¹Material: ACH = Alloy case-hardened; CHT = Carbon heat-treated.

²Indicates straight sidebar style.

Note: Dimensions are subject to change. Contact Engineering Chain Division of U.S. Tsubaki to obtain certified prints for design and construction.

U.S. Tsubaki, Inc.
Engineering Chain Division
(800)537-6140
www.ustsubaki.com



Jig Washer Chain

Jig Washer Chain

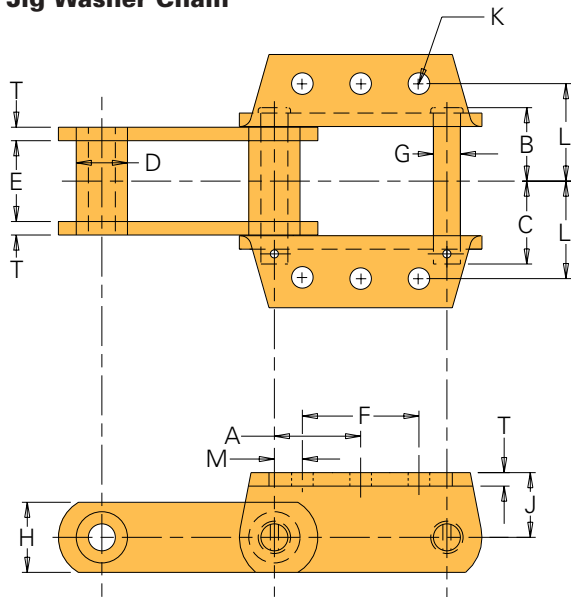

6826 Jig Washer Chain Specifications

All dimensions are in inches unless otherwise indicated.

Chain Number	Dwg. No.	Pitch	Chain Width				Pins		Bushings		Sidebars			Attachments					Approx. Weight (lbs./ft.)	
			Over-all (B+C)	Head to CL B	End to CL C	Inside Width E	Dia. G	Matl. ¹	Dia. D	Matl. ¹	Thick. T	Height H	Matl. ¹	A	F	J	M	L		K
6826 K1/K2 Ev. 2nd	19583	6.000	4.75	2.22	2.53	2.38	.88	AHTIH	1.50	ACH	.38	2.50x3	CHT	3.00	2.63	1.75	1.69	3.00	.53	15.5
6826 K1/K2 Ev. 3rd	19442	6.000	4.75	2.22	2.53	2.38	.88	AHTIH	1.50	ACH	.38	2.50x3	CHT	3.00	2.63	1.75	1.69	3.00	.53	14.0
6826 K1/K2 Ev. 4th	19448	6.000	4.75	2.22	2.53	2.38	.88	AHTIH	1.50	ACH	.38	2.50x3	CHT	3.00	2.63	1.75	1.69	3.00	.53	13.0

¹Material: AHTIH = Alloy heat-treated induction hardened; ACH = Alloy case hardened; CHT = Carbon heat-treated.



ENGINEERING CHAIN DIVISION

Drop Forged Rivetless Chain

X-Style Drop Forged Rivetless Chain with Extended Pins

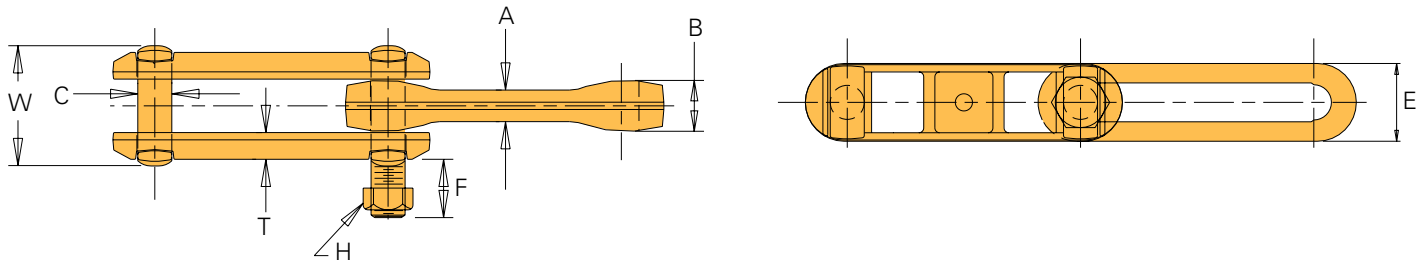

Standard Drop Forged Rivetless Chain

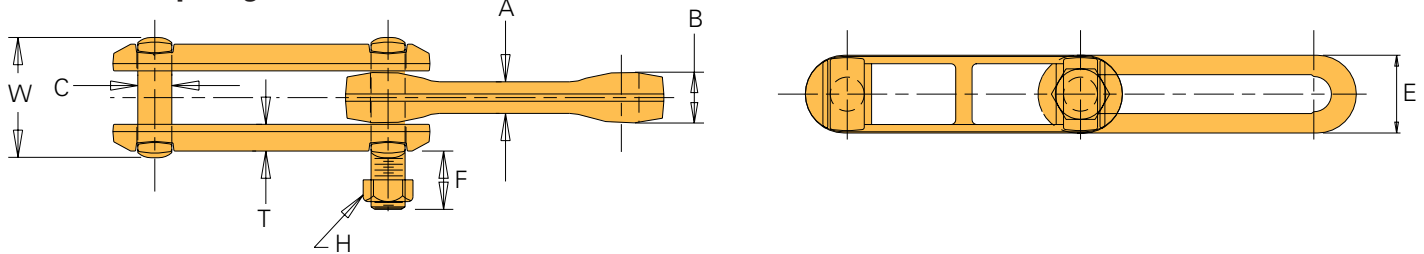

Drop Forged Rivetless Chain Specifications

All dimensions are in inches unless otherwise indicated.

Chain Number	Drawing Number	Pitch	Average Tensile Strength	A	B	C	E	T	W	Attachments			Approx. Weight (lbs./ft.)
										Space	F	H	
X-678	18371	6.031	85,000	.81	1.31	.88	2.00	.69	3.09	2 Ext. Pins Ev. 4th	1.50	.75	6.9
698	21652	6.031	130,000	1.00	1.56	1.13	2.52	.63	3.88	2 Ext. Pins Ev. 4th	1.50	.75	12.1

Indicates this chain is normally stocked.

Note: Dimensions are subject to change. Contact Engineering Chain Division of U.S. Tsubaki to obtain certified prints for design and construction.

U.S. Tsubaki, Inc.
 Engineering Chain Division
 (800)537-6140
www.ustsubaki.com

Mining

Standard Model

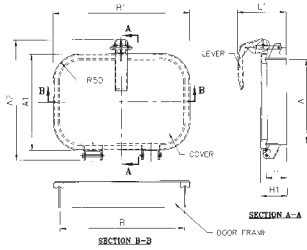

Large Model

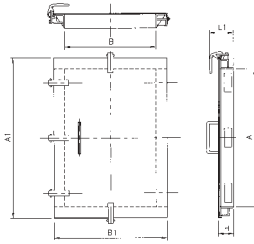

ENGINEERING CHAIN DIVISION

ONE-TOUCH INSPECTION DOOR®

STANDARD ONE-TOUCH INSPECTION DOOR SPECIFICATIONS

Dimensions are in inches unless otherwise indicated.

Style/Model No.		Door Frame				Cover					Lever			Approx. Weight (lbs.)	
		A	B	H	High Neck	A1	A2	B1	H1	High Neck	L1	High Neck	Qty.	Reg.	High Neck
Regular	High Neck			Reg.				Reg.					Reg.		
Mild Steel Body, Chrome-Plated Handle															
P1	P1H	5	8	2	4	6 1/4	8 1/2	9	2 1/2	4 1/2	4 1/2	6 1/2	1	4.5	6
P2	P2H	8	12	2	4	9	11 1/4	13	2 1/2	4 1/2	4 1/2	6 1/2	1	6.6	9.2
P3	P3H	13 3/4	19 3/4	2	4	15	17 1/4	20 3/4	2 1/2	4 1/2	4 1/2	6 1/2	2	13.2	17.6
P4		19 3/4	23 1/2	3	N/A	20 3/4	23 1/4	24 3/4	3 1/2	N/A	4 1/2	N/A	2	24.2	N/A
304 Stainless Steel Body, Chrome-Plated Handle															
Q1	Q1H	5	8	2	4	6 1/4	8 1/2	9	2 1/2	4 1/2	4 1/2	6 1/2	1	4.5	6
Q2	Q2H	8	12	2	4	9	11 1/4	13	2 1/2	4 1/2	4 1/2	6 1/2	1	6.6	9.2
Q3	Q3H	13 3/4	19 3/4	2	4	15	17 1/4	20 3/4	2 1/2	4 1/2	4 1/2	6 1/2	2	13.2	17.6
Q4		19 3/4	23 1/2	3	N/A	20 3/4	23 1/4	24 3/4	3 1/2	N/A	4 1/2	N/A	2	24.2	N/A
304 Stainless Steel Body, 304 Stainless Steel Handle															
R1	R1H	5	8	2	4	6 1/4	8 1/2	9	2 1/2	4 1/2	4 1/2	6 1/2	1	4.5	6
R2	R2H	8	12	2	4	9	11 1/4	13	2 1/2	4 1/2	4 1/2	6 1/2	1	6.6	9.2
R3	R3H	13 3/4	19 3/4	2	4	15	17 1/4	20 3/4	2 1/2	4 1/2	4 1/2	6 1/2	2	13.2	17.6
R4		19 3/4	23 1/2	3	N/A	20 3/4	23 1/4	24 3/4	3 1/2	N/A	4 1/2	N/A	2	24.2	N/A
316L Stainless Steel Body, Chrome-Plated Handle															
QS1	QS1H	5	8	2	4	6 1/4	8 1/2	9	2 1/2	4 1/2	4 1/2	6 1/2	1	4.5	6
QS2	QS2H	8	12	2	4	9	11 1/4	13	2 1/2	4 1/2	4 1/2	6 1/2	1	6.6	9.2
QS3	QS3H	13 3/4	19 3/4	2	4	15	17 1/4	20 3/4	2 1/2	4 1/2	4 1/2	6 1/2	2	13.2	17.6
316L Stainless Steel Body, 304 Stainless Steel Handle															
RS1	RS1H	5	8	2	4	6 1/4	8 1/2	9	2 1/2	4 1/2	4 1/2	6 1/2	1	4.5	6
RS2	RS2H	8	12	2	4	9	11 1/4	13	2 1/2	4 1/2	4 1/2	6 1/2	1	6.6	9.2
RS3	RS3H	13 3/4	19 3/4	2	4	15	17 1/4	20 3/4	2 1/2	4 1/2	4 1/2	6 1/2	2	13.2	17.6

Note: Inches are rounded to the nearest 1/4". ONE-TOUCH INSPECTION DOOR® is a registered trademark of Tsubaki Conveyor of America, Inc.

LARGE ONE-TOUCH INSPECTION DOOR SPECIFICATIONS

Dimensions are in inches unless otherwise indicated.

Model No.	Door Opening		Cover			Lever		Approx. Weight (lbs.)
	A	B	A1	B1	H	L1	Qty.	
L1	29 1/2	19 3/4	34 1/4	24 1/2	3 1/4	5 1/4	5	80
L2	39 1/4	25 1/2	44	30 1/4	3 1/4	5 1/4	6	111
L3	47 1/4	31 1/2	52	36 1/4	3 1/4	5 1/4	8	141

Note: Dimensions are rounded to the nearest 1/4".

Note: Dimensions are subject to change. Contact Engineering Chain Division of U.S. Tsubaki to obtain certified prints for design and construction.

U.S. Tsubaki, Inc.
Engineering Chain Division
(800)537-6140
www.ustsubaki.com



Engineering Chain Sprocket Selection Guidelines

U.S. Tsubaki manufactures a complete line of Engineering Chain Sprockets for your mining operation. To make ordering as easy as possible, Table 1 shows the general information you need to provide. On your order form, indicate the Sprocket Order No. This number is composed of the chain number, the hub type, the number of teeth, the locking device (if any is required), and the bore size.

Table 1 — Information Necessary to Order Sprockets

1. Chain Size	Number, type, or drawing number of the chain to be used on the sprocket. (The suitability of a sprocket depends on specific chain dimensions: chain pitch, rollers, bushing diameter, inside width of chain or roller face.)								
2. Teeth	The number of actual teeth on the sprocket. If applicable, the number of working teeth, mid-pitch relief, or gap-toothed construction should be specified. This is necessary when driving conveyors with special through-rods or attachments which will interfere with the engagement. Special outer diameters are sometimes required to clear attachments.								
3. Material	a. Steel Plate welded hub, plain or with flame hardened teeth b. Cast Iron, plain, or hard rim c. Cast Steel, plain or with flame hardened teeth d. Special materials such as stainless steel, bronze, etc. State preference and alternate if acceptable								
4. Hub Type	<table border="1"> <thead> <tr> <th>Plate Only</th> <th>Hub One Side</th> <th>Hub Both Sides</th> <th>Offset Hubs on Both Sides</th> </tr> </thead> <tbody> <tr> <td>Type A</td> <td>Type B</td> <td>Type C</td> <td>Type C Offset</td> </tr> </tbody> </table> <p>Shear Pin Hubs: Type A is entirely self-contained with sprocket bored for running fit over flanged hub. Type B has sprocket bored for running fit over shaft. Material: Steel plate welded hub.</p>	Plate Only	Hub One Side	Hub Both Sides	Offset Hubs on Both Sides	Type A	Type B	Type C	Type C Offset
Plate Only	Hub One Side	Hub Both Sides	Offset Hubs on Both Sides						
Type A	Type B	Type C	Type C Offset						
5. Exact Diameter of Shaft Bore	Show special tolerances; keyway size; keyway location when required. If not a standard keyway specify: straight, tapered, square or flat and dimensions. (See Table 2.)								
6. Set Screws	If not a standard, specify type. If more than one or special position is required, indicate the number and location. (See Table 3.)								
7. Hub Dimensions	These measurements are usually manufacturers standard. However, for special orders, outside diameter and through length should be specified. For Type C Offset Sprockets, specify the length from the centerline of the chain to each side and the total through length.								

Table 2 — Tolerances for Boring Sprockets

Diameter of Shaft	Tolerances	
1" and under	Nominal	plus .001"
Over 1" to 2"	Nominal	plus .002"
Over 2" to 3"	Nominal	plus .003"
Over 3" to 4"	Nominal	plus .004"
4" and over	Nominal	plus .005"

Table 3 — Standard Keyways and Set Screws

Diameter of Shaft	Keyseat		Diameter of Set Screw
	Width	Depth	
1/2-9/16	1/8	1/16	1/8
5/8-7/8	3/16	3/32	3/16
1 1/16-1 1/4	1/4	1/8	1/4
1 1/4-1 3/8	5/16	5/32	5/16
1 3/8-1 1/2	3/8	3/16	3/8
1 1/2-1 7/8	1/2	1/4	1/2
1 7/8-2 1/8	5/8	5/16	5/8
2 1/8-2 1/4	3/4	3/8	3/4
2 1/4-2 3/8	7/8	7/16	7/8
2 3/8-2 1/2	1	1/2	1
2 1/2-2 7/8	1 1/4	5/8	1 1/4

All dimensions are in inches unless otherwise specified. Note: If not a standard keyway or set screw, call the U.S. Tsubaki Engineering Chain Division for assistance.