

TORQUE LIMITER

- Sizes : 42 sizes
- Torque range : 0.3~950kgf-m
- Bore range : $\phi 9\sim\phi 130$
- Non asbestos friction plate

TORQUE LIMITER (Friction Type Overload Clutch)

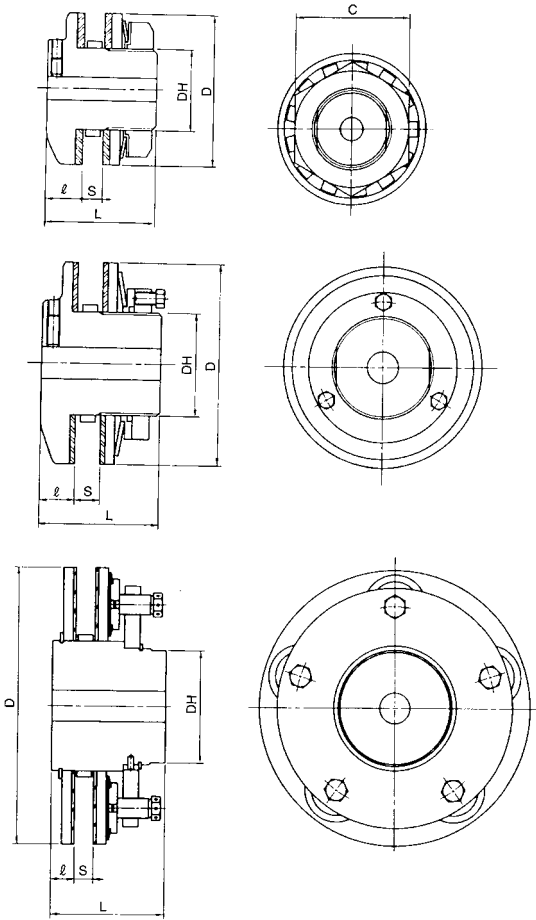

Dimensions and ratings

(Dimensions in mm)

Size	Torque Range (N-m)	Rough Bore	Max. Bore	Bush. Length	O.D. of Bush.	Bore for Center Member	D	DH	L	ℓ	S (max.)	C	Adjust. Nut	Adjust. Bolt	Set Screw	Weight (kgf)
TL200-1	2.9~9.8	7	14	3.8	30	30	50	24	29	6.5	7	38	M24 P1.0	—	—	0.2
TL200-2	6.8~20															
TL250-1	6.9~27	10	22	4.5	41	41	65	35	48	16	9	50	M35 P1.5	—	M5	0.6
TL250-2	14~54															
TL350-1	20~74	17	25	4.5	49	49	89	42	62	19	16	63	M42 P1.5	—	M6	1.2
TL350-2	34~149															
TL500-1	47~210	20	42	6.5	74	74	127	65	76	22	16	—	M65 P1.5	M8 P1.0 3pcs.	M8	3.5
TL500-2	88~420															
TL700-1	116~569	30	64	9.5	105	105	178	95	98	24	29	—	M95 P1.5	M10 P1.25 3 pcs.	M10	8.4
TL700-2	223~1,080															

Size	Torque Range (kgf-m)	Rough Bore	Max. Bore	Bush. Length	O.D. of Bush.	Bore for Center Member	D	DH	L	ℓ	S (max.)	Adjustment Bolt	Weight (kgf)
TL10-16	40~130	30	72	12.5	135	135	254	100	115	23	24	M18 P1.5 8pcs.	21
TL10-24	60~190												
TL14-10	90~272	40	100	15.5	183	183	356	145	150	31	29	M26 P1.5 5 pcs.	52
TL14-15	200~400												
TL20-6	250~500	50	130	15.5	226	226	508	185	175	36	31	M32 P1.5 6 pcs.	117
TL20-12	470~950												

Overload safety devices design concept

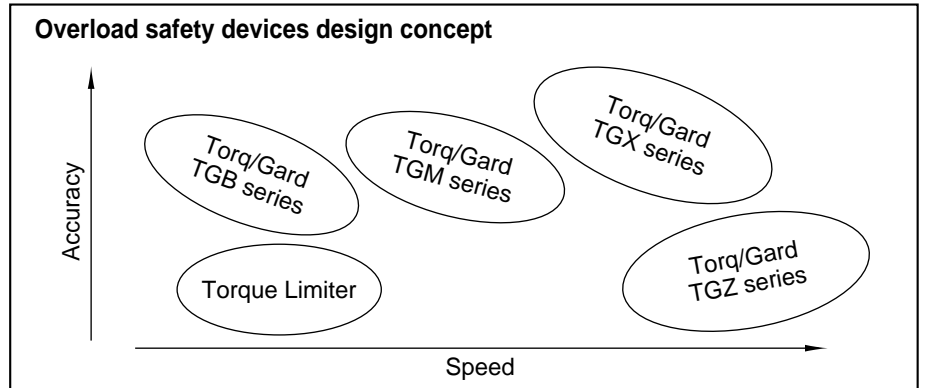

FEATURES

- Automatic reset
- Adjustable torque
- Reversible

APPLICATIONS

- Packaging machines
- Paper processing machines
- Crushers
- Parking towers